

OUR WORLD

STARTER

Series Editors
Joan Kang Shin
JoAnn (Jodi) Crandall

SECOND EDITION • WORKBOOK

Unit 0	2
Unit 1 My School.....	5
Unit 2 My Toys.....	9
Unit 3 My Family.....	13
Unit 4 My Body	17
Units 1-4 Review	21
Unit 5 Stories.....	23
Unit 6 I Like Food	27
Unit 7 Clothes	31
Unit 8 Animals.....	35
Units 5-8 Review	39
Writing	41
Cutouts	57

Unit 0

LANGUAGE IN USE

1 Listen. Look and circle. TR: 0.1

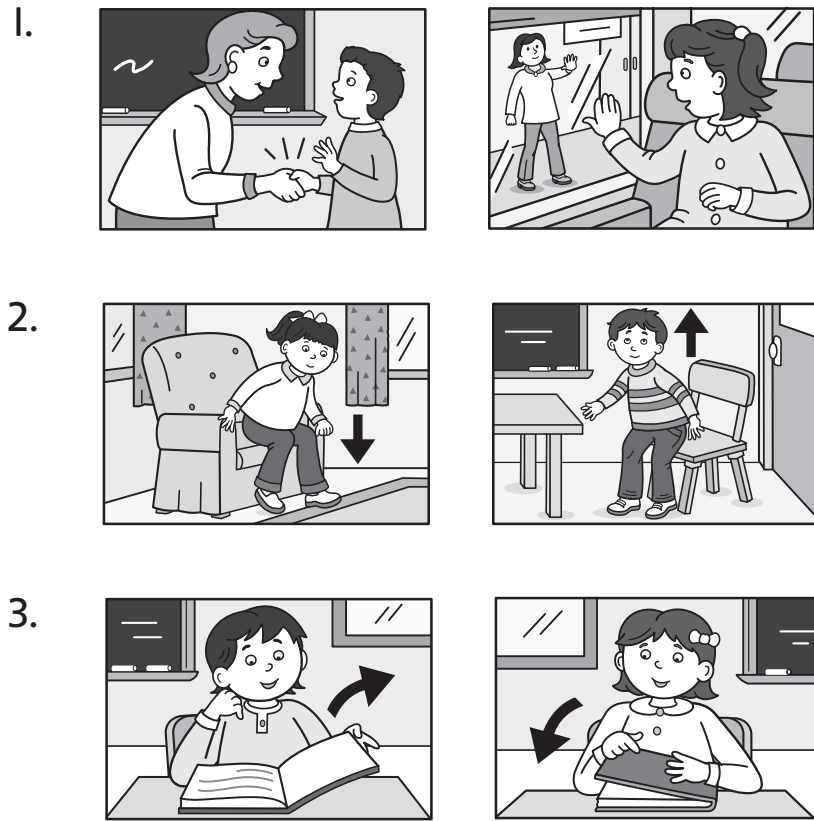

2 Listen and circle. TR: 0.2

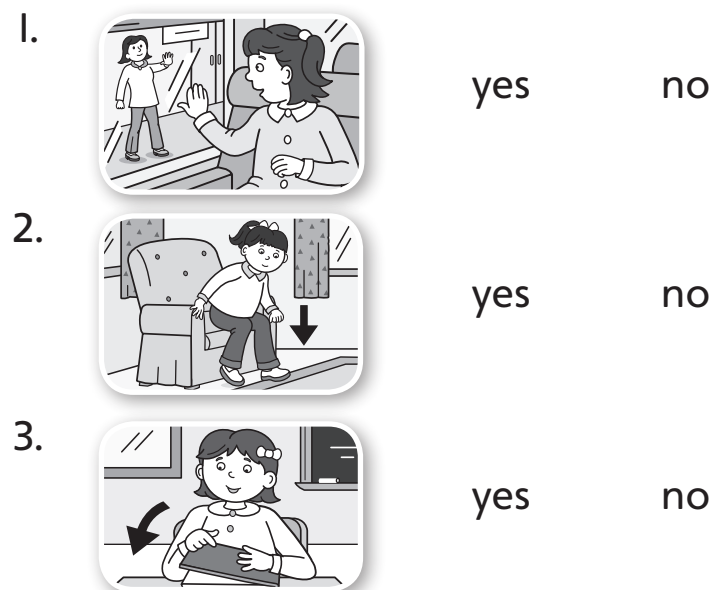

COLORS AND NUMBERS

1 Listen. Color and say. TR: 0.3

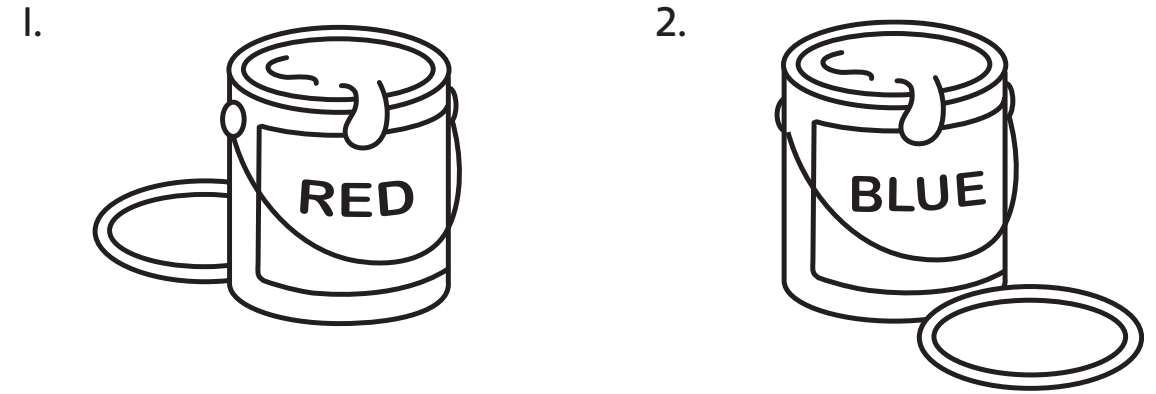

2 Listen. Color and say. TR: 0.4

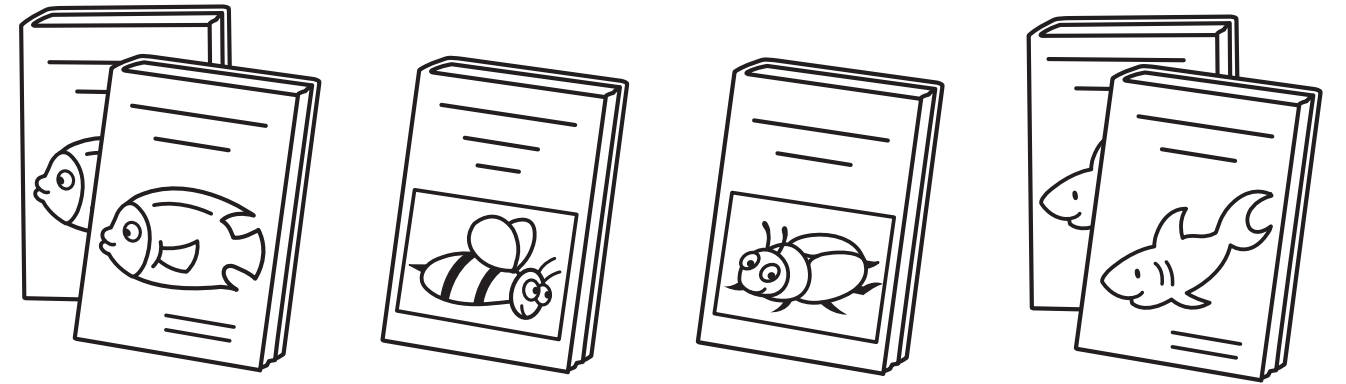

3 Look. Count and write.



4 Listen. Draw and color. TR: 0.5

THE SOUNDS OF ENGLISH

1 Listen and say. TR: 0.6

2 Listen and look. Which word is different? Circle. TR: 0.7

1.



2.



3 Listen and chant. Point. TR: 0.8

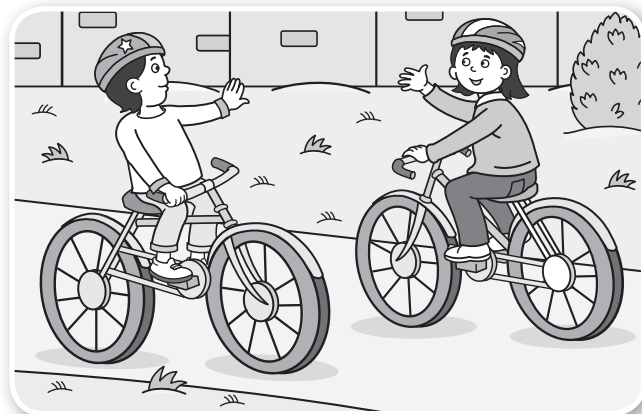

Hello, hello.
Hi there, hi.

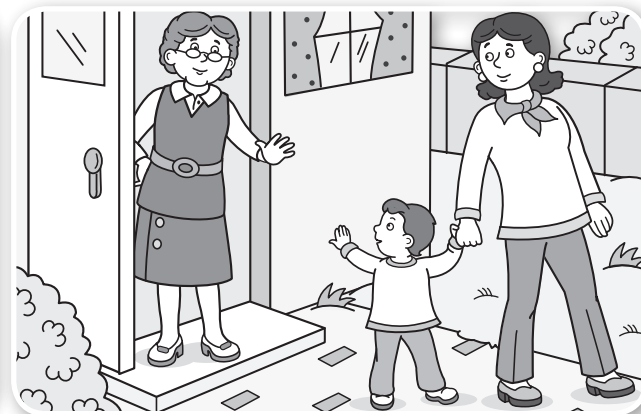

Time to go.
Bye, goodbye!

Unit 1

My School

VOCABULARY

1 Listen. Look and circle. TR: 1.1

1.



2.



3.



4.

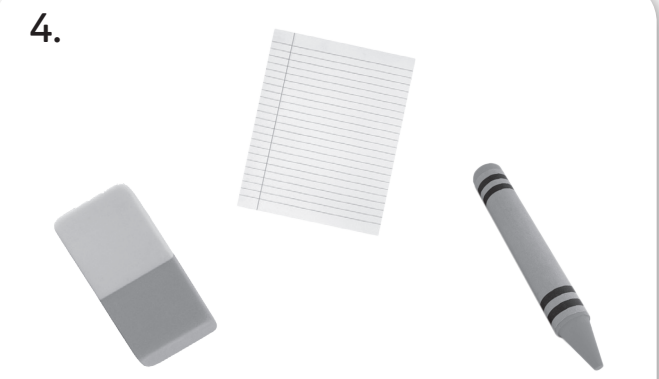

5.



6.



LANGUAGE IN USE

1 Listen and say. TR: 1.2

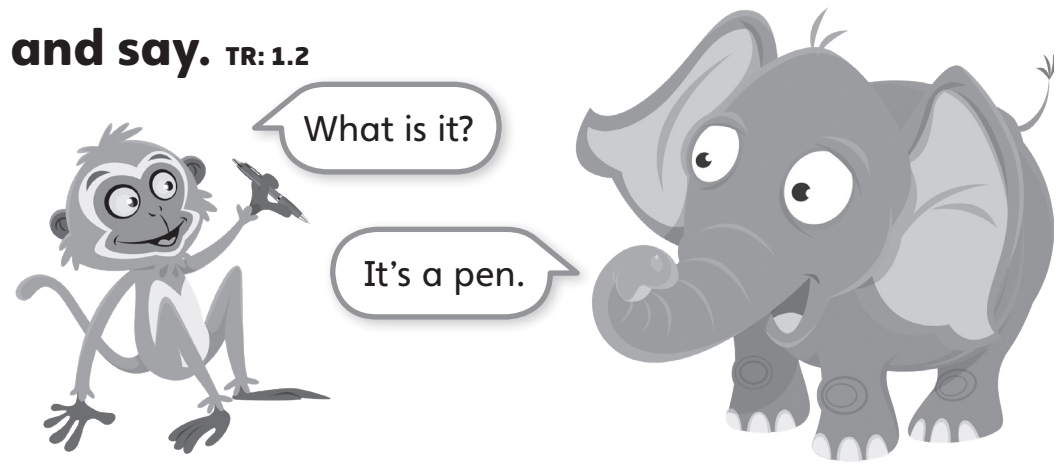

2 Cut out the cards in the back of the workbook.

Listen. Glue the cards. Say. TR: 1.3



3 Match. Say.



COLORS AND NUMBERS

1 Listen. Color and say. TR: 1.4

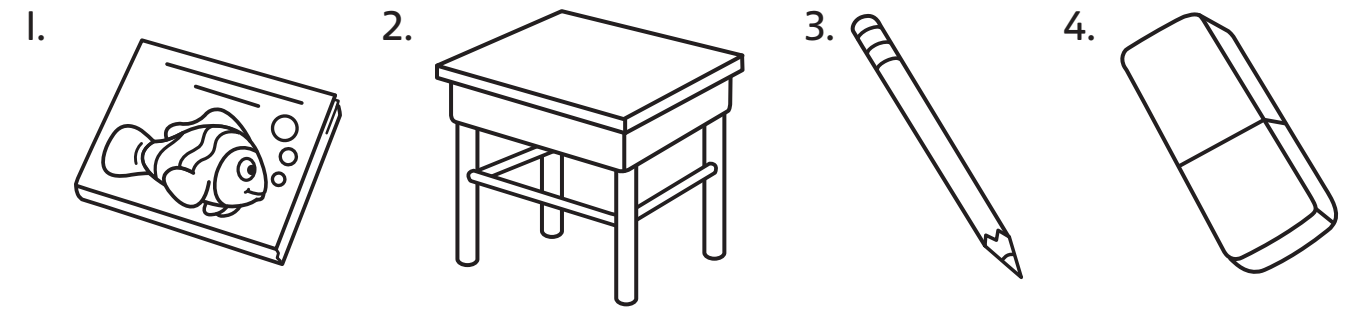

2 Listen. Color. Count and say. TR: 1.5

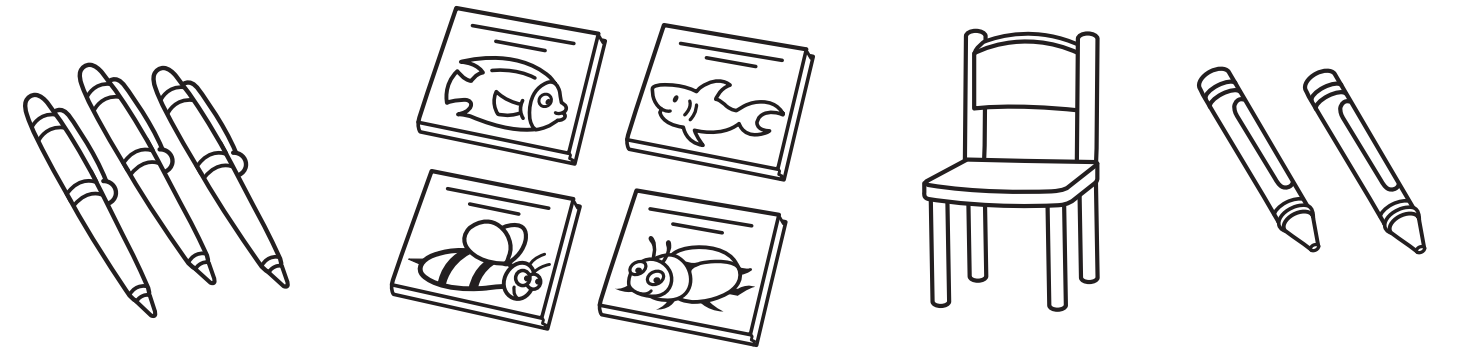

3 Listen. Count and write. TR: 1.6



THE SOUNDS OF ENGLISH

1 Listen and say. TR: 1.7

2 Listen and look. Which word is different? Circle. TR: 1.8

1.



2.



3.



3 Listen and chant. Say a new verse. TR: 1.9

I have some



I have a



I have a



Let's draw again!

I have an



I have a



I have some



Let's draw again!

Unit 2

My Toys

VOCABULARY

1 Listen. Look and circle. TR: 2.1

1.



2.

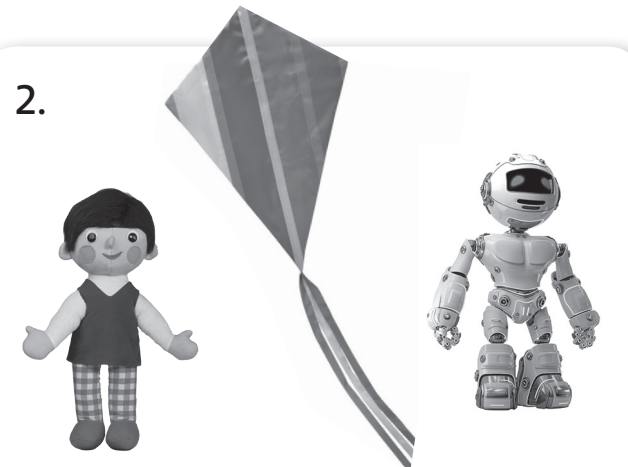

3.



4.

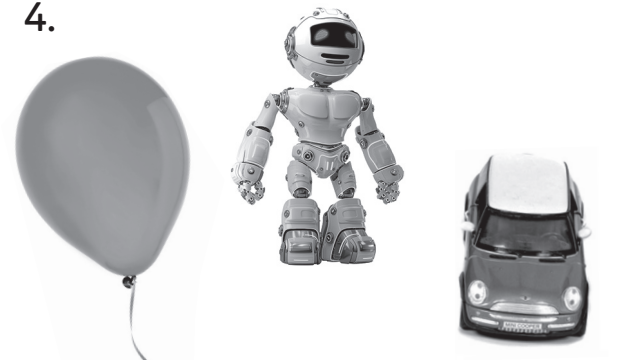

5.



6.



LANGUAGE IN USE

1 Listen and say. TR: 2.2

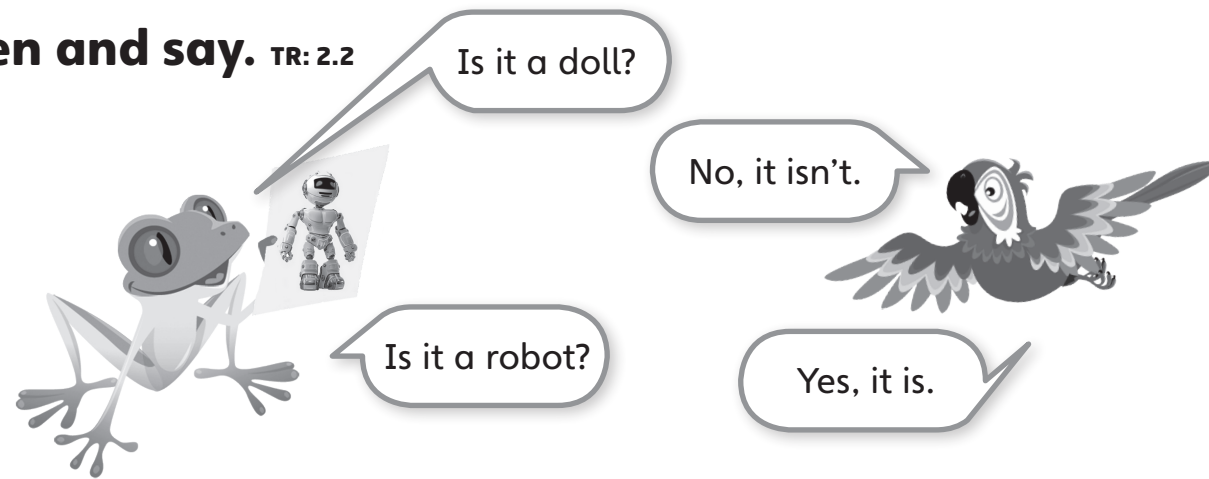

2 Cut out the cards in the back of the workbook. Listen. What is it? Glue the cards. Say. TR: 2.3



3 Draw your favorite toy. Color. What is it? Say.

COLORS AND NUMBERS

1 Listen. Color and say. TR: 2.4

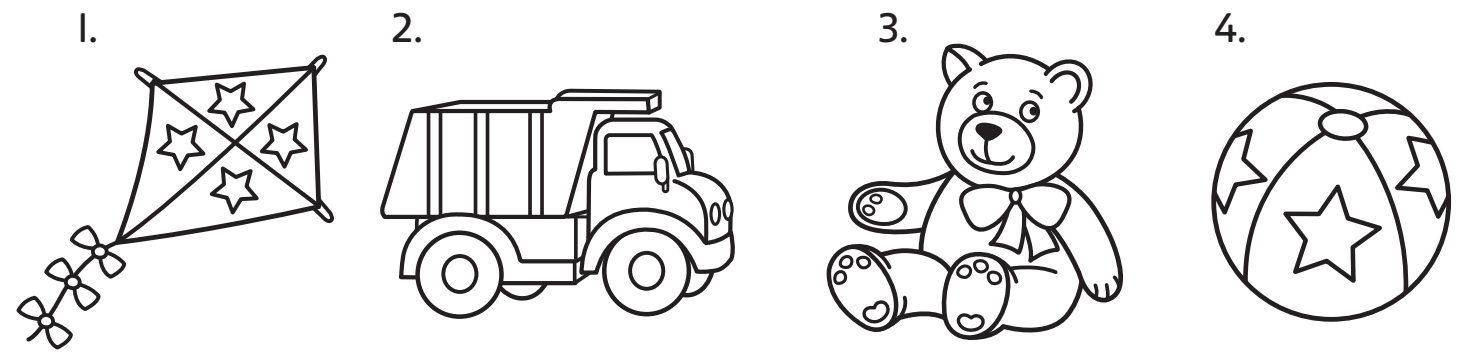

2 Listen. Color. Count and say. TR: 2.5

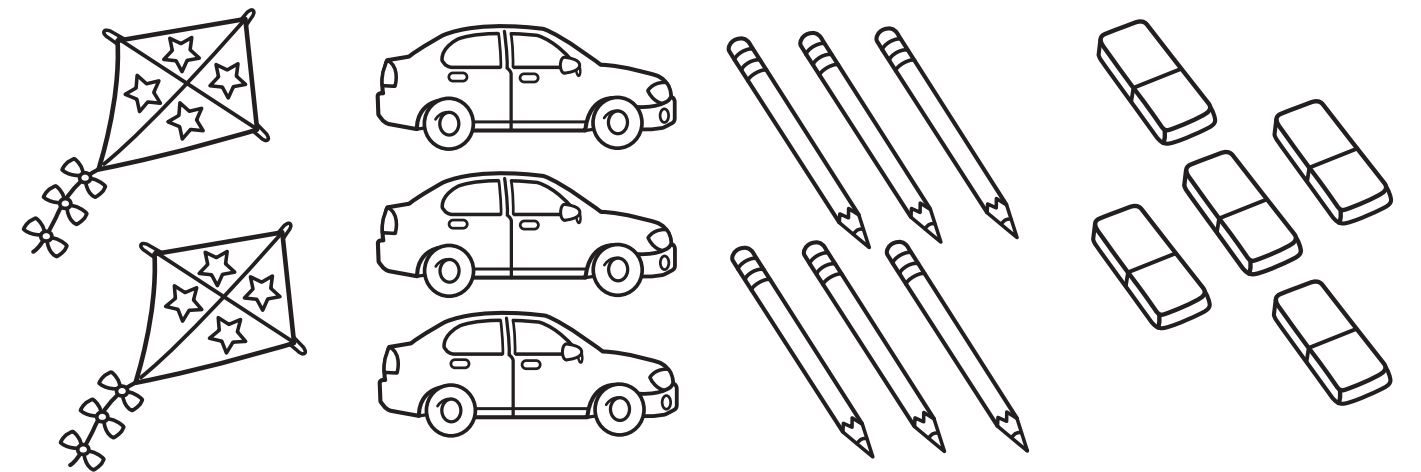

3 Listen. Count and write. TR: 2.6

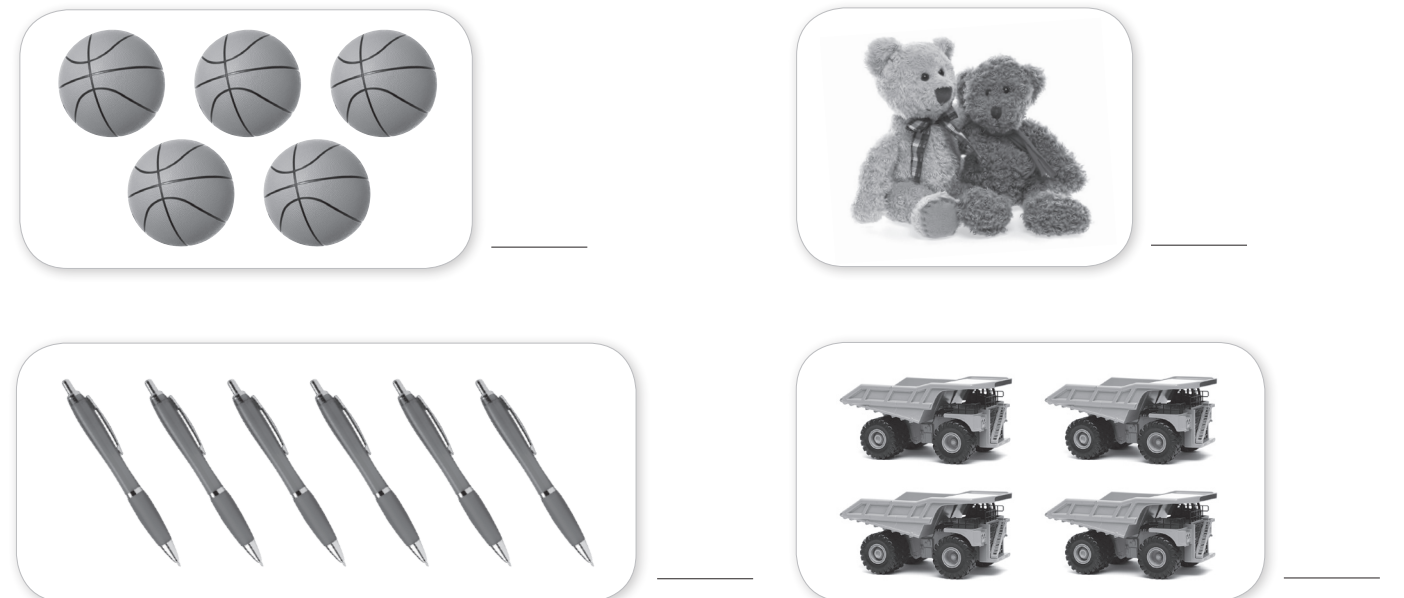

THE SOUNDS OF ENGLISH

- 1 Listen and say.** TR: 2.7
- 2 Listen and look.** Which word is different? Circle. TR: 2.8

1.



2.



3.



- 3 Listen and chant.** Say a new verse. TR: 2.9

and
 and more toys.

 and
 for girls and boys!

and
 and more toys.

 and
 for girls and boys!

Unit 3

My Family

VOCABULARY

- 1 Listen and look.** Draw a line. TR: 3.1



1

2

3

4

5

6

7

8

9

10



LANGUAGE IN USE

1 Listen and say. TR: 3.2



2 Listen and circle. TR: 3.3



3 Listen and say. TR: 3.4

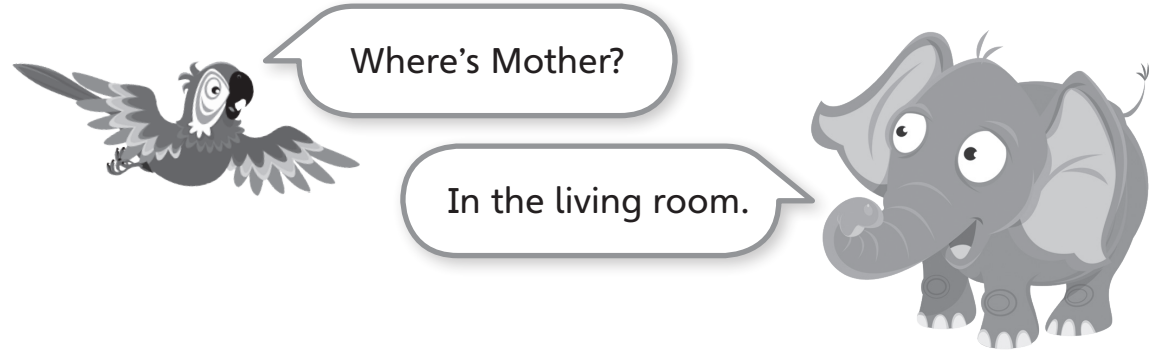

4 Cut out the cards in the back of the workbook. Listen. Where's the family? Glue the cards. Say. TR: 3.5

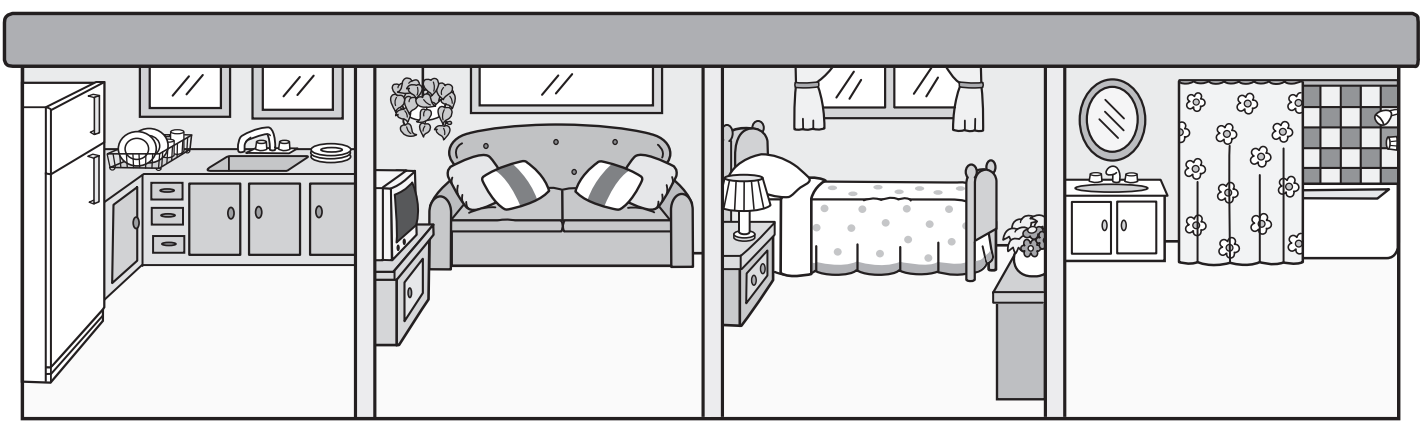

COLORS AND NUMBERS

1 Listen. Color and say. TR: 3.6

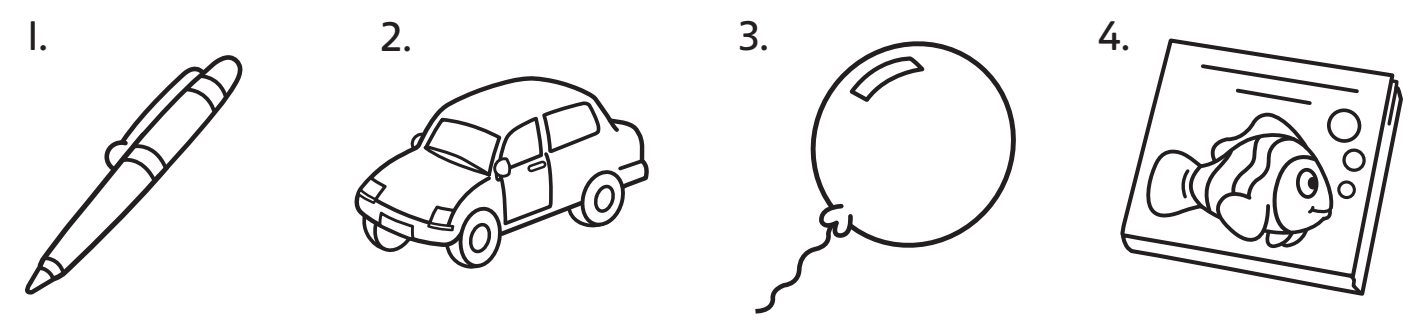

2 Listen. Color. Count and say. TR: 3.7

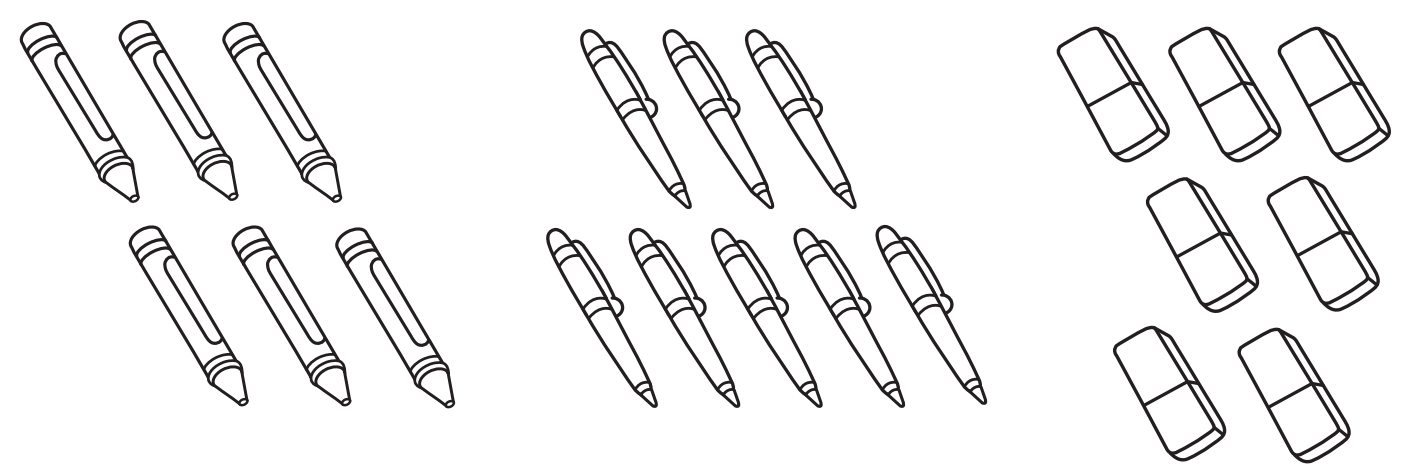

3 Listen. Count and write. TR: 3.8

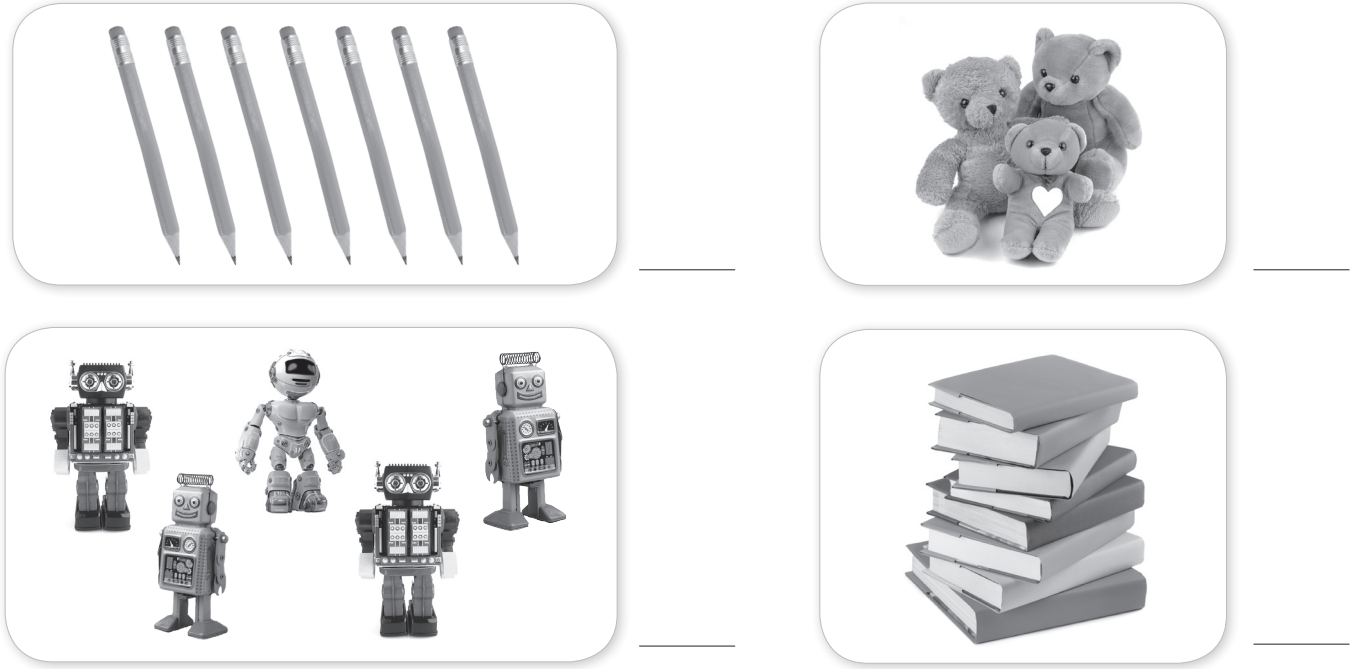

THE SOUNDS OF ENGLISH

1 Listen and say. TR: 3.9

2 Listen and look. Which word is different? Circle. TR: 3.10

1.

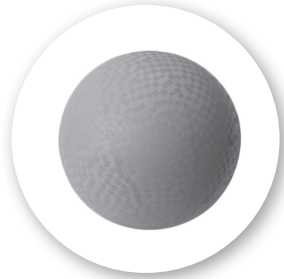

2.



3.



3 Listen and chant. Say a new verse. TR: 3.11

I love my 



Oh yes, I do.

My  and my 

love him, too.

I love my 

Oh yes, I do.

My  and my 

love her, too.

Unit 4

My Body

VOCABULARY

1 Listen and look. Draw a line. TR: 4.1



1 5

2 6

3 7

4 8

9